

# Mercedes-Benz Garagenmaße

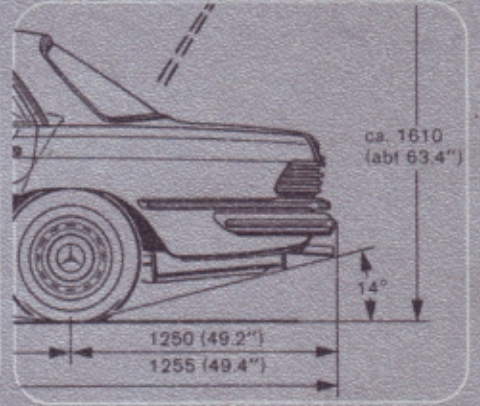
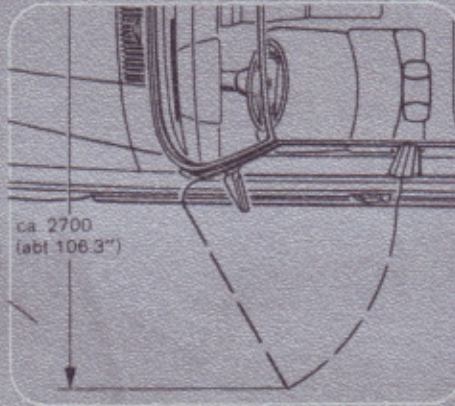
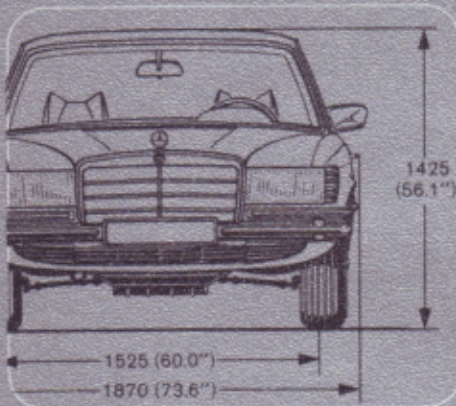

# Garagenmaße

**D**ie Angaben für Bodenfreiheit, vorderer und hinterer Überhangwinkel sowie Rampenwinkel sind statische Werte ohne dynamisches Einfedern, gemessen bei einer mittleren Belastung (fahrfertig nach DIN 70020 + 3 Personen à 65 kg bei Limousinen bzw. 2 Personen à 65 kg bei Sportwagen/SL- und SLC-Typen). Sie beziehen sich auf den Neuzustand des Fahrzeugs und können sich im Laufe der Zeit durch Setzen der Aggregate in der Lagerung oder Aufhängung sowie durch dynamisches Einfedern verringern. Es ist deshalb bei der Auslegung von Garagen bzw. Garagenzufahrten hierfür ein Sicherheitszuschlag vorzusehen, ein weiterer Zuschlag ist für die Berücksichtigung der gewünschten Zuladung erforderlich.

Es ist weiterhin noch zu beachten, daß wir bei unseren Angaben nur die Anlage von geradlinig geführten Rampen angenommen haben, für schraubenförmig anzulegende Zufahrten gelten diese Werte daher nicht.



# 200 D 200 220 D 230 240 D 250 300 D

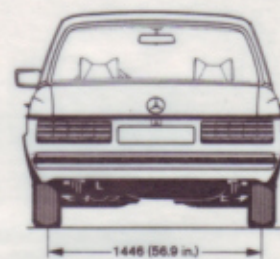
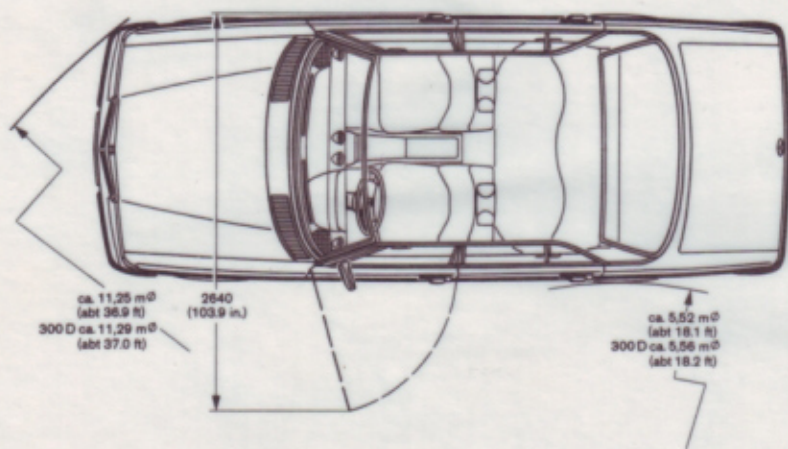
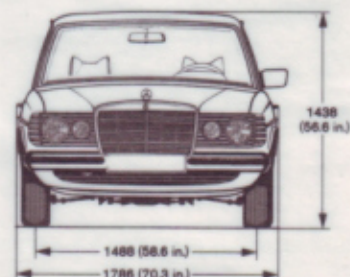
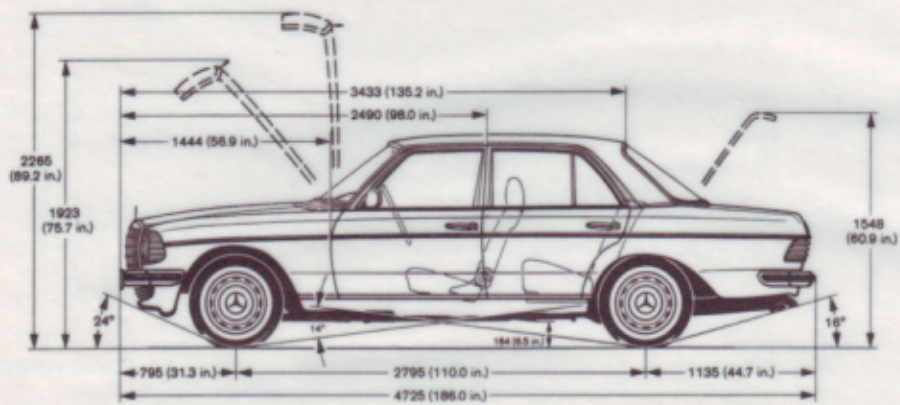

# 280 280 E

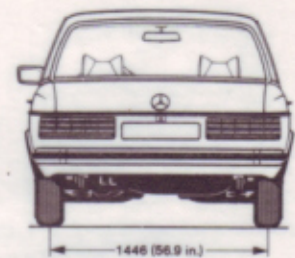
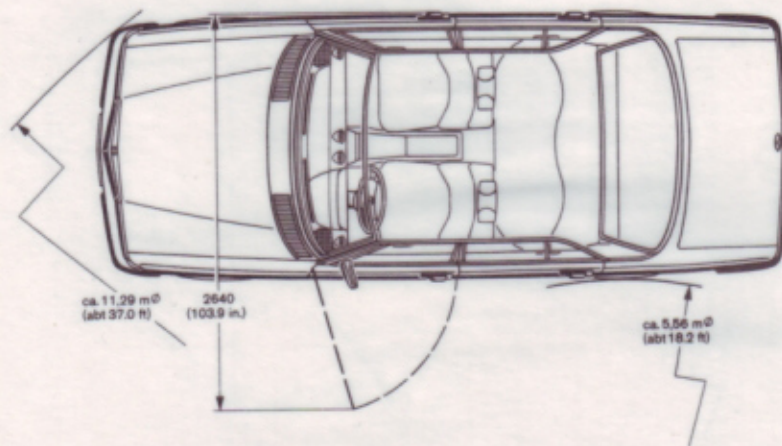
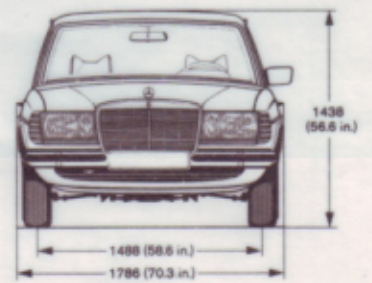
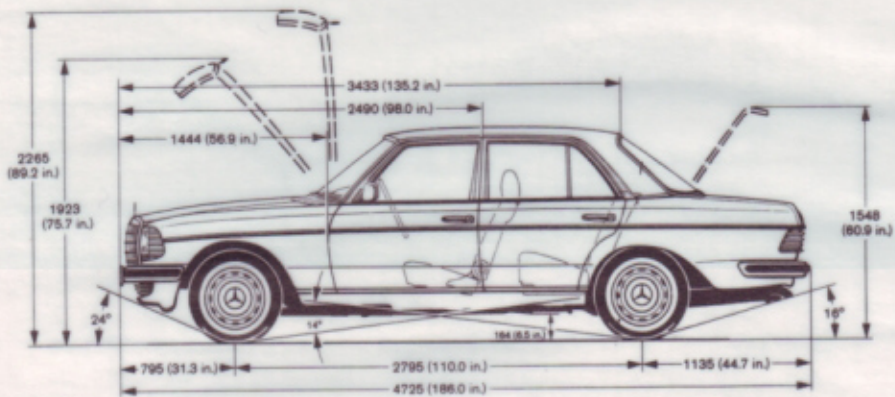

200 D	200
220 D	230.4
240 D	230.6
240 D 3.0	250

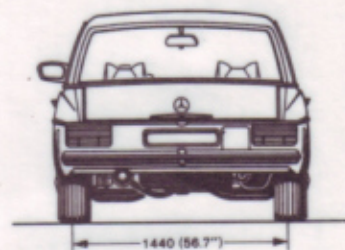
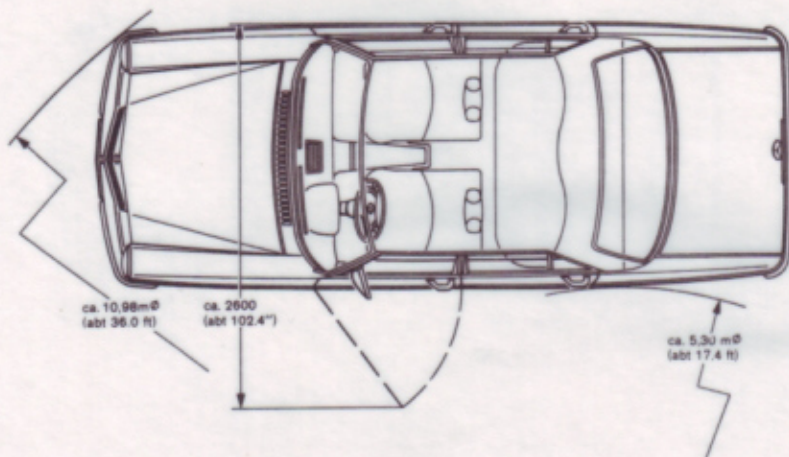
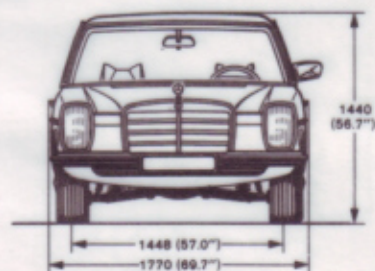
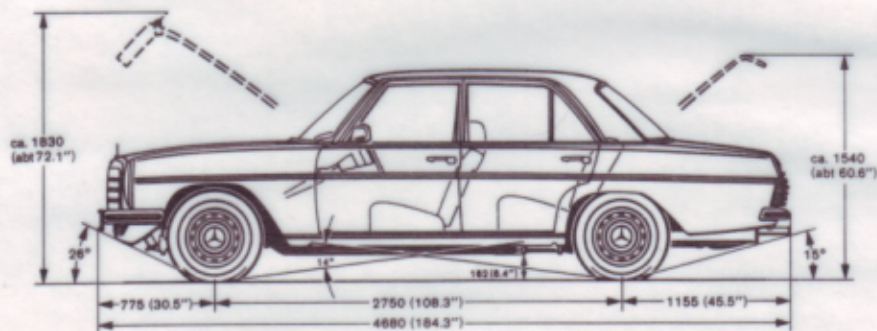

# 280 280 E

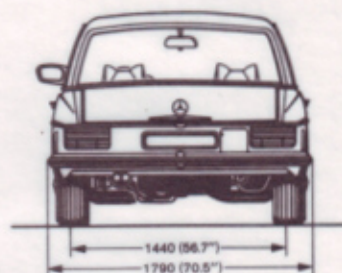
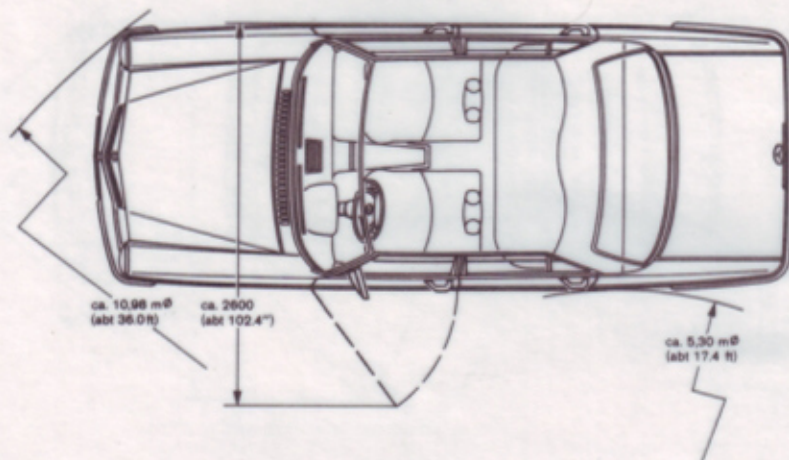
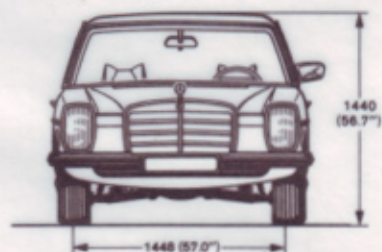
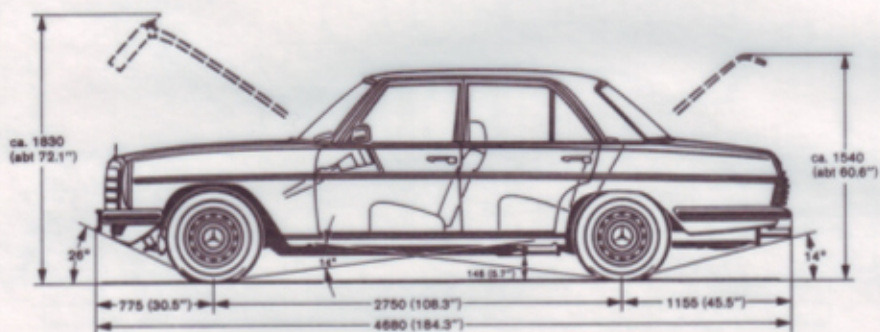

# 240 D 230.6

Radstand 3400 mm

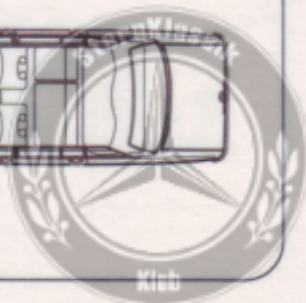
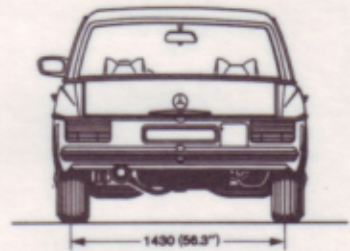
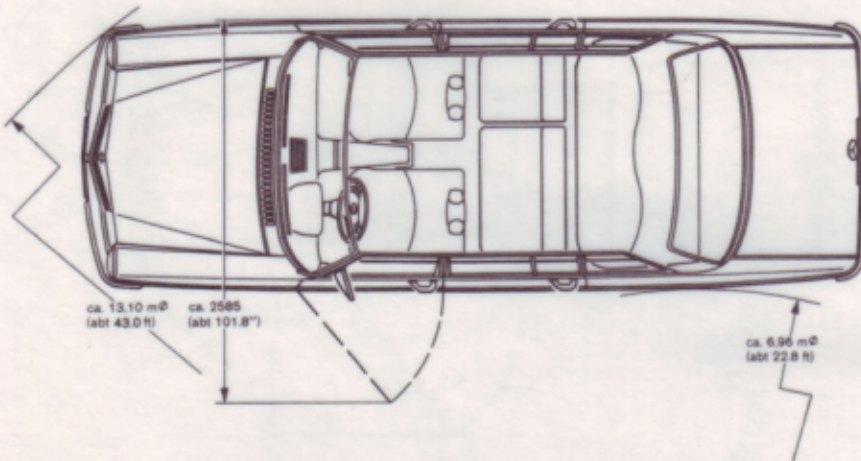
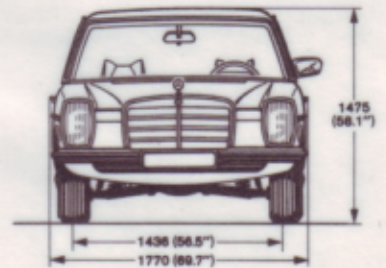
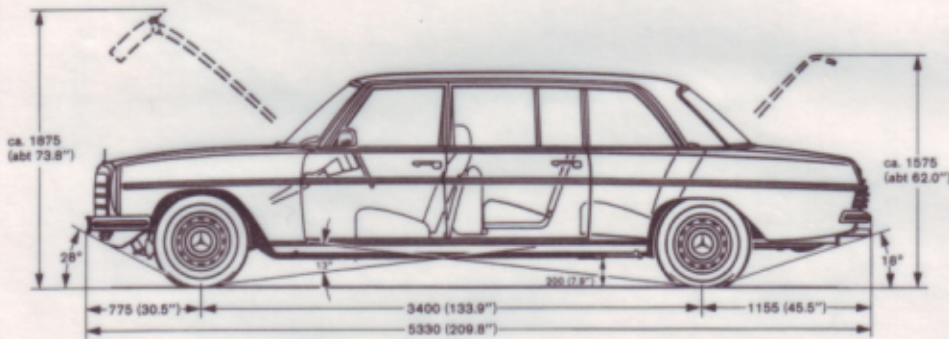

# 250 C

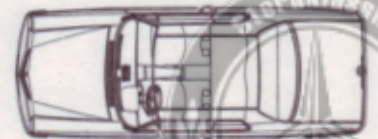
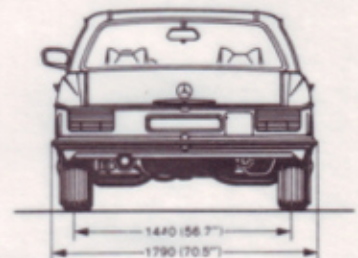
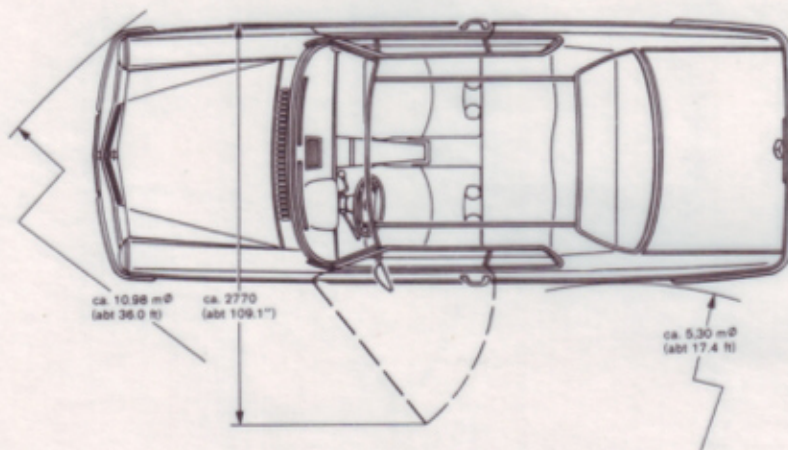
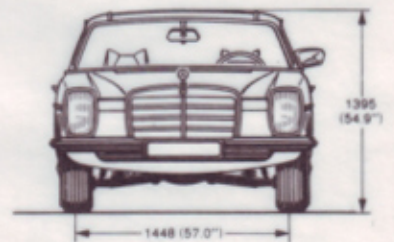
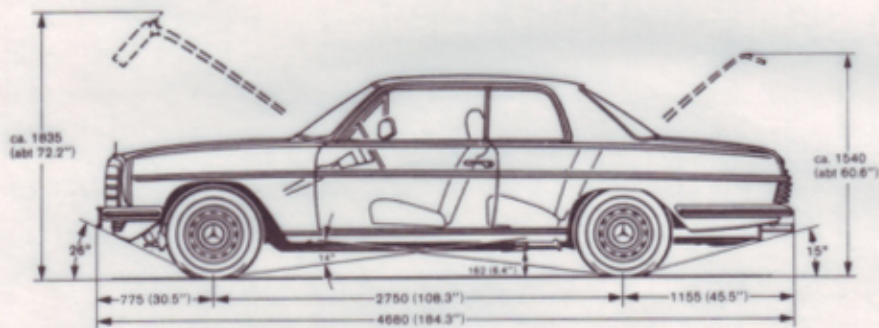



# 280 C 280 CE

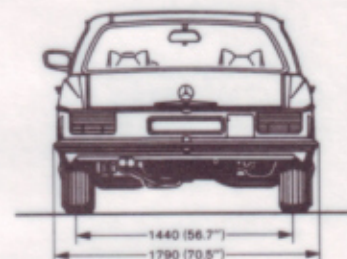
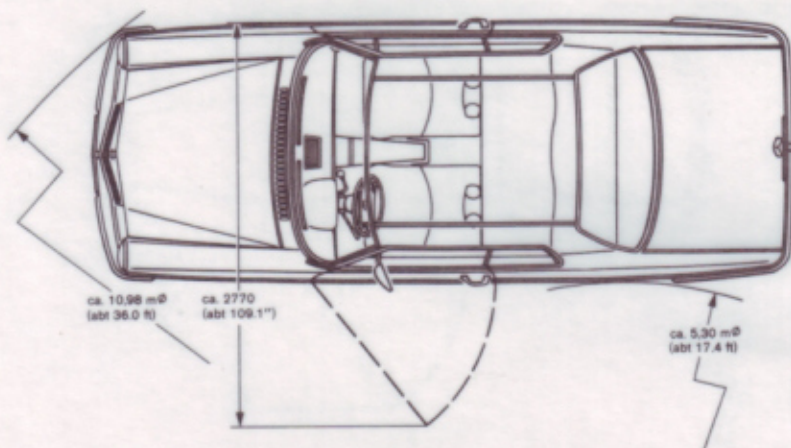
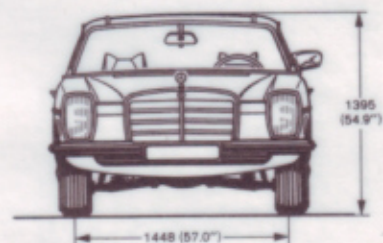
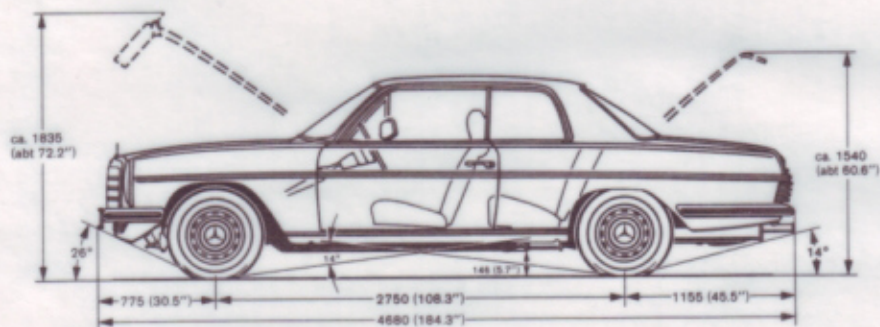

# 280 S 280 SE 350 SE 450 SE

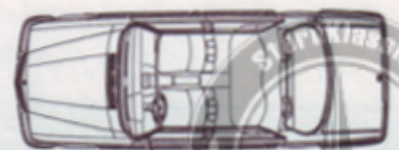
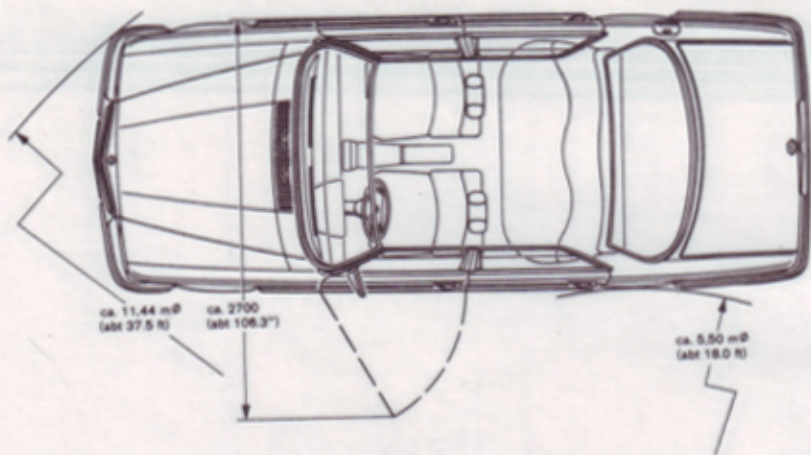
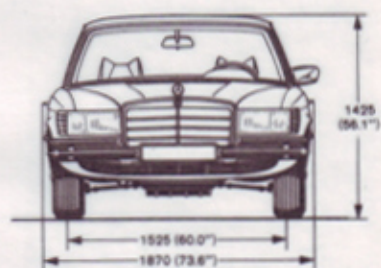
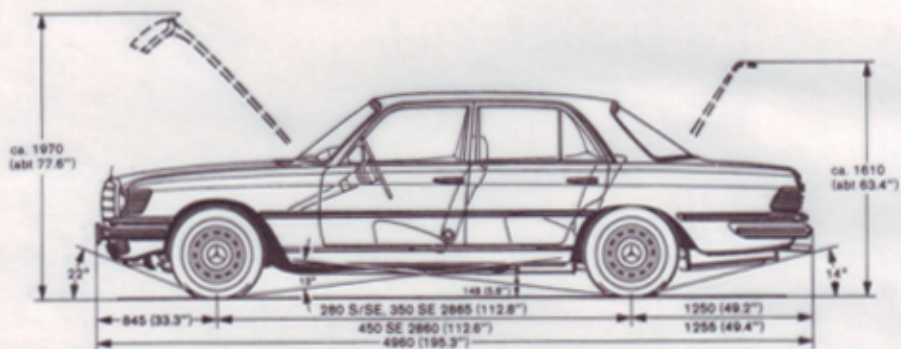

# 280 SEL 350 SEL 450 SEL

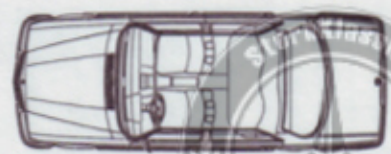
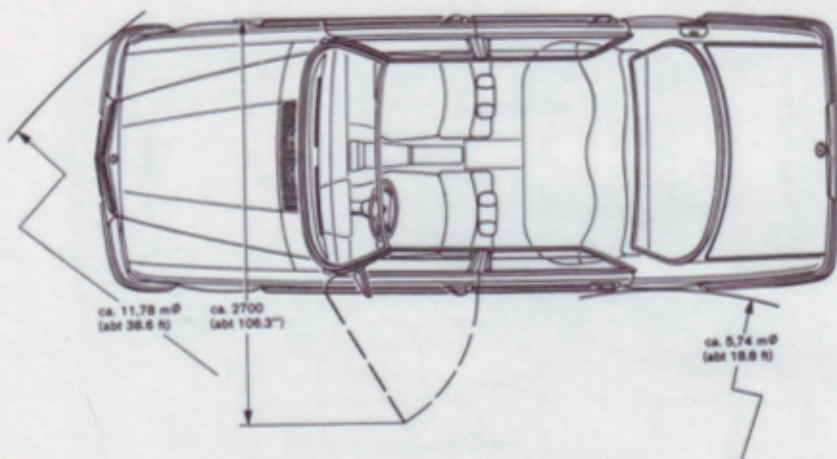
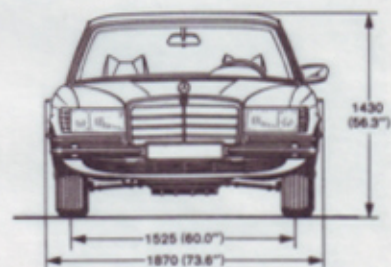
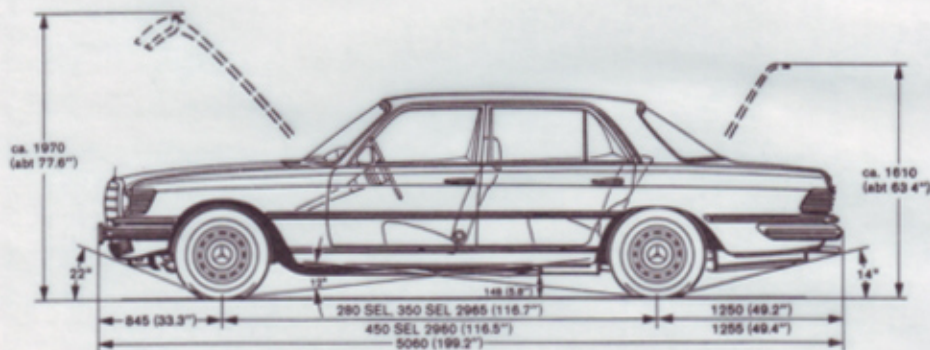

# 450 SEL 6.9

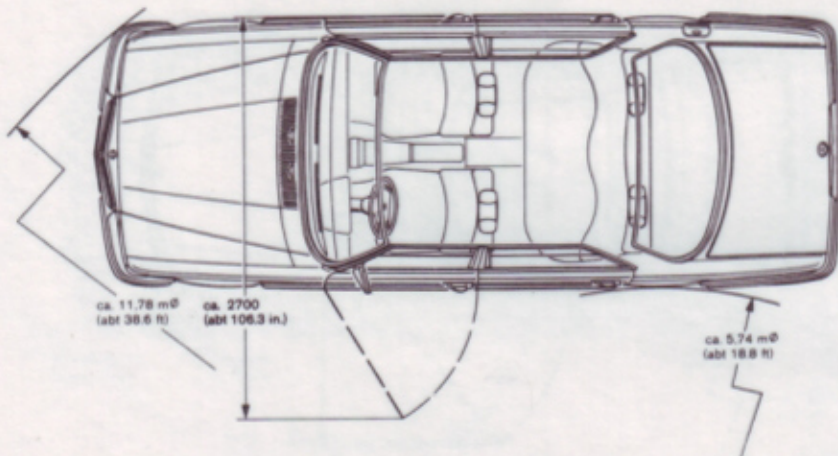
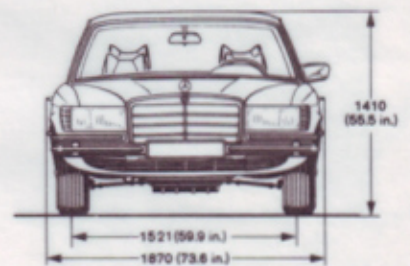
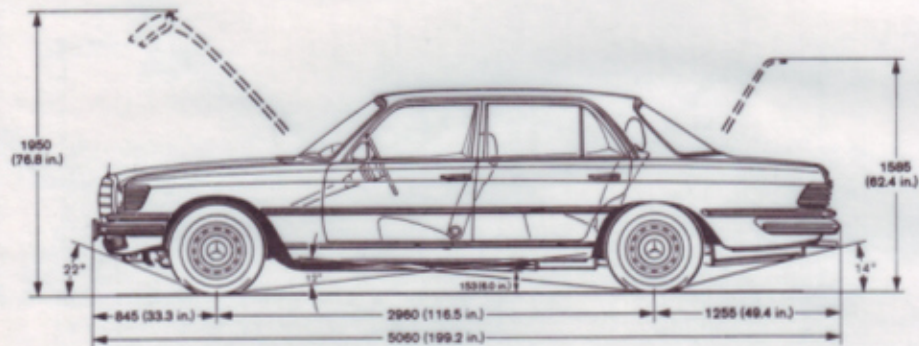

# 280 SL 350 SL 450 SL

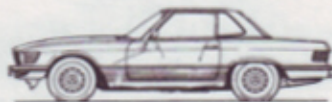
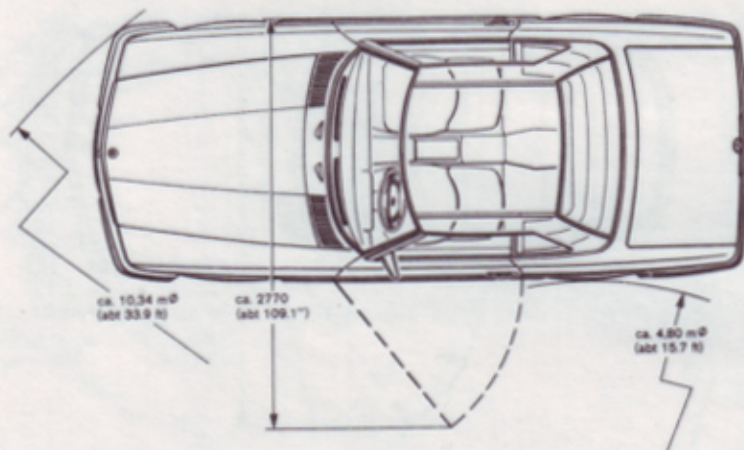
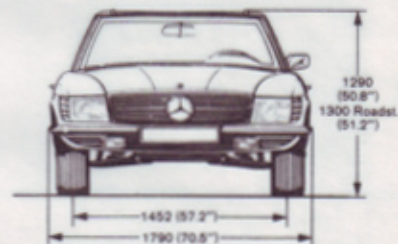
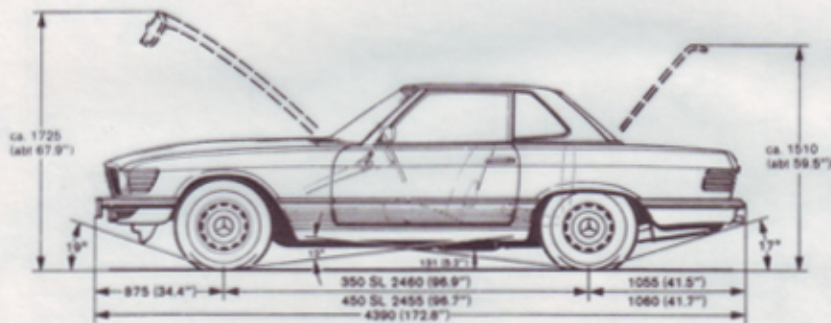

# 280 SLC 350 SLC 450 SLC

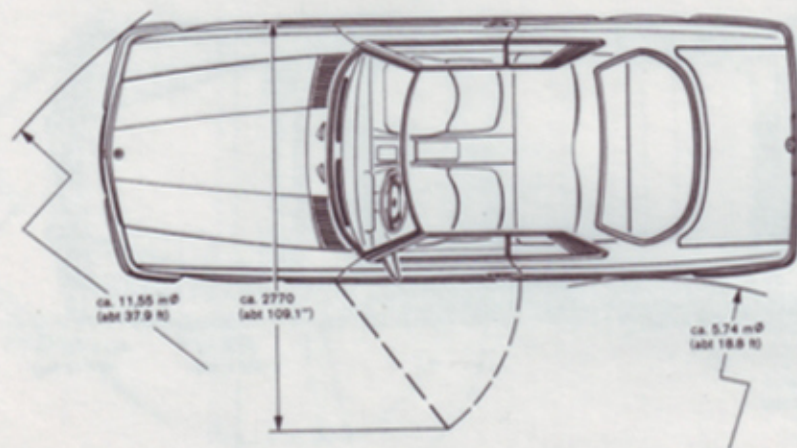
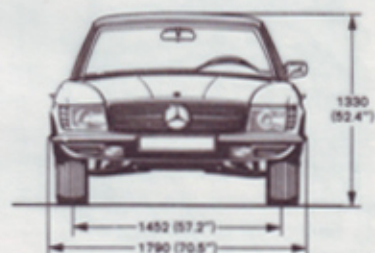
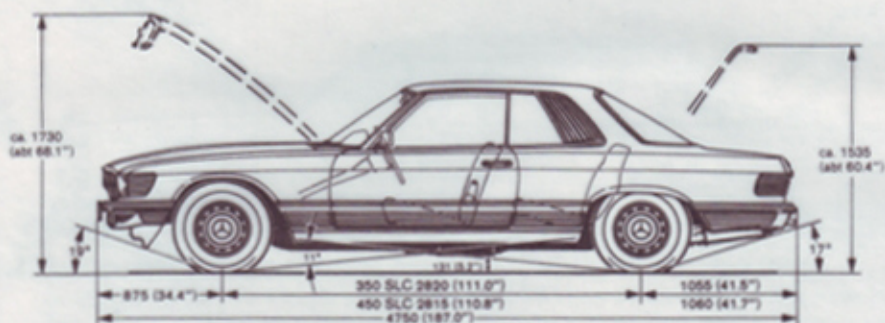

# 600

Pullman

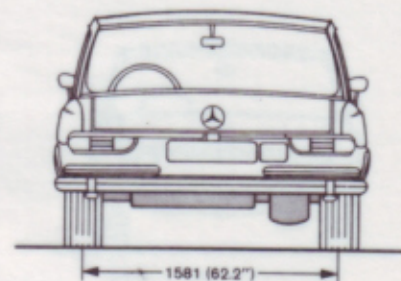
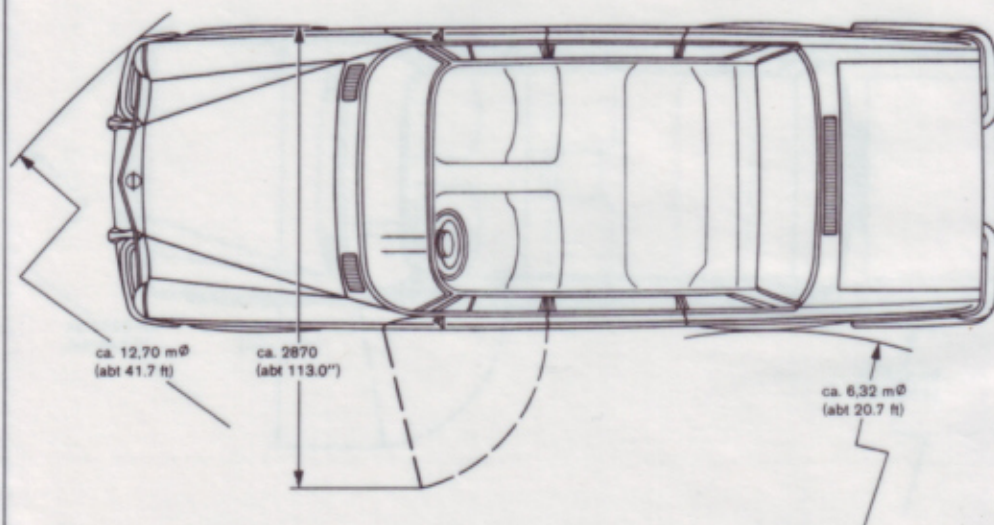
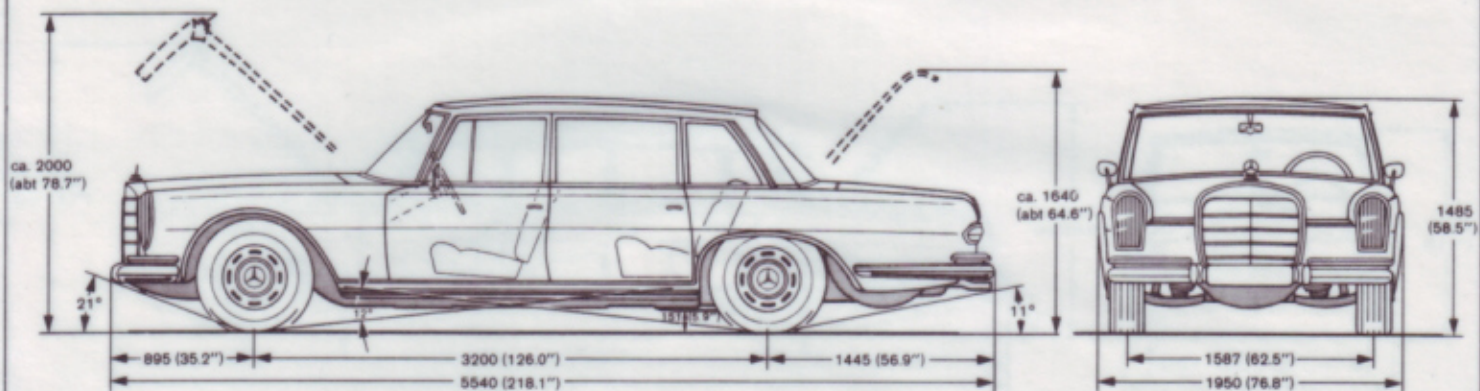

# 600 Pullman

